



aerospace  
climate control  
electromechanical  
filtration  
fluid & gas handling  
hydraulics  
**pneumatics**  
process control  
sealing & shielding



# Electronic, Electric, Analogue and IO-Link Sensors P8S Series

PDE2815TCUK



ENGINEERING YOUR SUCCESS.

**Important**

Before attempting any external or internal work on the cylinder or any connected components, make sure the cylinder is vented and disconnect the air supply in order to ensure isolation of the air supply.

**Note**

All technical data in this catalogue are typical data only.  
Air quality is essential for maximum cylinder service life (see ISO 8573).

**WARNING**

**FAILURE OR IMPROPER SELECTION OR IMPROPER USE OF THE PRODUCTS AND/OR SYSTEMS DESCRIBED HEREIN OR RELATED ITEMS CAN CAUSE DEATH, PERSONAL INJURY AND PROPERTY DAMAGE.**

This document and other information from Parker Hannifin Corporation, its subsidiaries and authorized distributors provide product and/or system options for further investigation by users having technical expertise. It is important that you analyze all aspects of your application and review the information concerning the product or system in the current product catalog. Due to the variety of operating conditions and applications for these products or systems, the user, through its own analysis and testing, is solely responsible for making the final selection of the products and systems and assuring that all performance, safety and warning requirements of the application are met. The products described herein, including without limitation, product features, specifications, designs, availability and pricing, are subject to change by Parker Hannifin Corporation and its subsidiaries at any time without notice.

**SALE CONDITIONS**

The items described in this document are available for sale by Parker Hannifin Corporation, its subsidiaries or its authorized distributors. Any sale contract entered into by Parker will be governed by the provisions stated in Parker's standard terms and conditions of sale (copy available upon request).

**Contents****Page**

P8S Sensors	
Product Overview .....	4
Technical Data .....	5
Dimensions .....	6
Connection Type and Diagram .....	7
Ordering Data .....	8
P8S CPS Sensors	
Product Overview .....	10-11
Technical Data .....	10-11
Ordering Data .....	10-11
Dimensions .....	10-11
Connection Type and Diagram .....	10-11
Mountings and Brackets .....	13
Connectors and Cables .....	14
P8S Pneumatic Sensors	15
Product Overview .....	15
Dimensions .....	15
Mounting and Bracket .....	15

## P8S Electronic and Reed Sensors

The P8S Series magnetic cylinder sensor enables quick, precise and contactless sensing of the piston's position in cylinders. It is easy to mount, can be used in numerous applications and offers an outstanding price-performance ratio.



### Product Overview

As the term magnetic switch suggests, these are operated by magnetic fields; another description widely used is magnetic „SENSOR“. As our eyes sense change of light, our ears sense the change of sound, magnetic sensors / switches sense the change of magnetic flux in pneumatic and hydraulic cylinders. When magnetic sensors sense a magnetic field it will give a switching signal, through a control circuit, allowing sensing or control operation to be achieved.

Because of the characteristics of magnetic sensors they can sense a change of magnetic field relative to the position of the magnet, such as in a pneumatic or hydraulic cylinder, whereby the magnet is attached to a moving piston and thus the position of the moving part (ie Piston) can be detected.

The magnet is mounted on the piston of the cylinder and thus moves with the piston.

The magnetic sensor (switch) is fixed either directly to the cylinder or with an additional mounting bracket. When the piston (magnet) moves to the position under a magnetic sensor, the switch will operate due to the change of the magnetic field and give a switching signal.

Thus the position of the piston can be identified and a resulting signal generated to continue the sequence of a circuit.

Magnetic sensors available can be classified into two different groups, they are sensors with contacts which are called mechanically operated or reed sensors and the other type is sensors without contacts and are called solid state type or electronic.

Parker P8S Series sensors are suitable for use with a large range of Sensors. They can either be inserted directly into the cylinder tube extrusion or mounted using additional brackets. For direct mounting the sensor is positioned within the cylinder sensor groove, offering mechanical protection, then securely clamped into position by a simple turn of a screw. For other cylinder versions there are a number of optional sensors brackets that clamp to the cylinder and offer other mounting positions. To easy installation there

are several cable lengths available with either M8 connector or flying lead. The electronic sensors are "Solid State", i.e. they have no moving parts. They are provided with short-circuit protection and transient protection as standard. The built-in electronics make the sensors suitable for applications with high on and off switching frequency where long service life is required.

Please note that for low temperature applications sensors are normally specified for full performance down to -30°C only. High temperature cylinders do not have a magnetic piston and therefore cannot be used with sensors.

## Technical Data

Square body design, insert straight in T-slot, screw 1/4 turn

	Electronic PNP   NPN	Electric Reed
<b>Cylinder type:</b>	Profile with T-slot	
<b>Cylinder type with adaptor:</b>	Profile with S-slot (dovetail)   Tie rods   Round cylinders	
<b>Installation:</b>	Quarter turn, fixed by allen key 2.5 mm or flathead screwdriver	
<b>Housing length:</b>	29.5 mm	29.5 mm 5 - 30 V AC/DC
	24 mm (NAMUR ATEX)	29.5 mm 5 - 120 V AC/DC
		32.5 mm 5 - 230 V AC/DC
<b>Output Type:</b>	PNP   NPN	Reed
<b>Switching (on/off) switching frequency:</b>	± 1,000 Hz	± 400 Hz
<b>Output Function:</b>	Normally Open (NO)   Normally Closed (NC) 3-wire	Normally Open (NO)   Normally Closed (NC) 2-wire Normally Open (NO) 3-wire
<b>Enclosure rating:</b>	IP67	
<b>Supply Voltage:</b>	10 to 30 V DC	5 to 30   5 to 120   5 to 230 V AC/DC 2-wire, 3-wire depending on type
	8.2 to 20 V DC (NAMUR 1GD)   10 to 26 V DC (ATEX 3GD)	
<b>Power consumption:</b>	<= 8 mA	-
	<= 10 mA (NAMUR, ATEX)	-
<b>Voltage drop:</b>	<= 2 V	<= 3.5 V 2-wire   <= 0.1 V 3-wire
	<= 2.2 V (NAMUR, ATEX)	-
<b>Continuous output current I<sub>a</sub>:</b>	<= 100 mA	<= 100 mA 3-wire
	<= 60 mA (NAMUR)   <= 50 mA (ATEX)	<= 500 mA (DC)   <= 300 mA (AC)
<b>Switching capacity:</b>	-	<= 6 W
<b>Protection class:</b>	III	III   II 2-wire depending on type III 3-wire
<b>Response sensitivity:</b>	2.6 to 3.3 mT	2.1 to 3.4 mT
	2.8 mT (NAMUR, ATEX)	-
<b>Overrun distance:</b>		10 mm
	9 mm (NAMUR, ATEX)	-
<b>Hysteresis:</b>	<= 0.8 mT	-
	<= 0.5 mT (NAMUR, ATEX)	-
<b>Repeatability:</b>		<= 0.1 mT
<b>Reverse polarity protection:</b>	Yes	No 2-wire
	-	Yes 3-wire
<b>Short circuit protection:</b>	Yes	-
<b>Power-up pulse protection:</b>	Yes (NAMUR, ATEX)	-
<b>Ambiant operating temperature range:</b>	-30 to +80 °C (PUR cable)   -30 to +70°C (PVC cable)	
	-25 to +80 °C (NAMUR 1GD)   -20 to +50°C (ATEX 3GD)	
<b>Shock and vibration resistance:</b>	30 g 11 ms / 10 ... 55 Hz, 1 mm	
<b>EMC:</b>	According to EN 60947-5-2	
<b>International standard:</b>	CE   C UL US   RoHs   Ex   IEC   IEC Ex	
<b>Housing material:</b>	Plastic polyamid PA12	
<b>Screw material:</b>	Stainless steel	
<b>Cable material:</b>	PUR (Polyurethane)   PVC (Polyvinyl Chloride)	
<b>Conductor cross-section:</b>	0.14 mm <sup>2</sup>   0,12 mm <sup>2</sup> depending on type 0.14 mm <sup>2</sup> (NAMUR, ATEX)	
<b>Indication LED colour:</b>	Yellow, no LED reed NC	
<b>Connector:</b>	M8R (knurled nuts)   None (Flying lead)	

Dimensions in mm (inch)

PNP, NPN Output 10 to 30 V DC

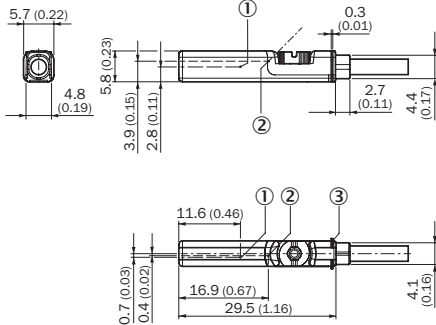

- ① Position sensor element
- ② Indication LED
- ③ Retaining ribs

Reed Output 5 to 230 V AC/DC

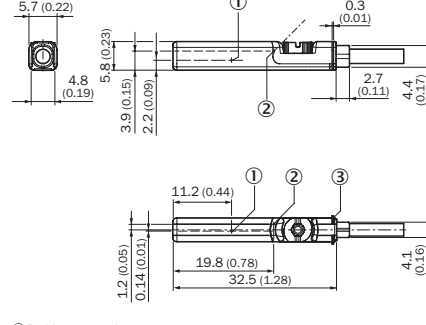

- ① Position sensor element
- ② Indication LED
- ③ Retaining ribs

Reed Output 5 to 30 V AC/DC

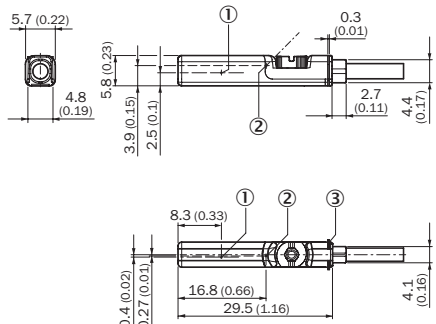

- ① Position sensor element
- ② Indication LED
- ③ Retaining ribs

Reed Output 5 to 120 V AC/DC

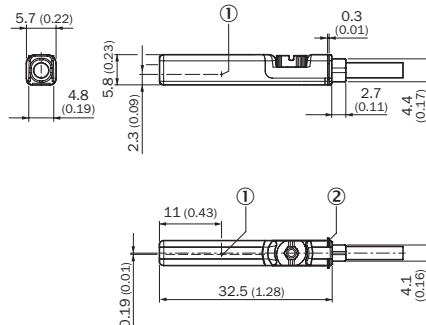

- ① Position sensor element
- ② Retaining ribs

NAMUR ATEX 1G, 1D, ATEX 3G, 3D

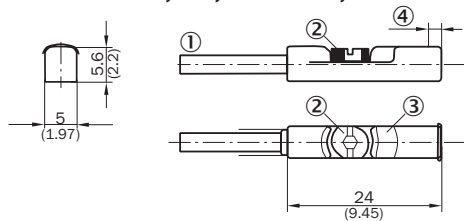

- ① Connection
- ② Fixing screw
- ③ Indication LED
- ④ Position of sensor element; short overrun distance: 2 mm; long overrun distance: 1.7 mm

Connector M8R

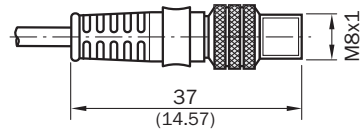

Installation

Square body design, Insert straight in T-slot, screw 1/4 turn

With Adaptor in S-Dovetail Slot

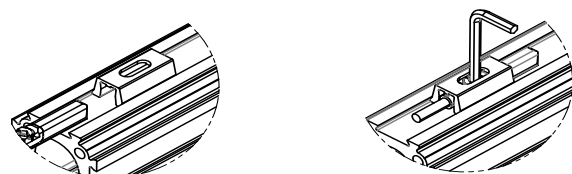

**Note:**  
The adaptor is delivered with each sensor.

Without Adaptor directly in T-Slot

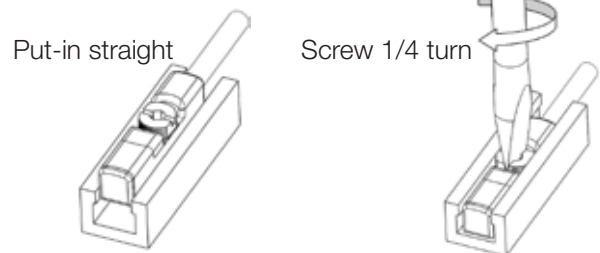

Connection type and diagram

PNP NO

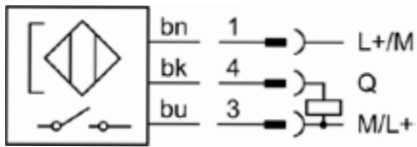

PNP NC

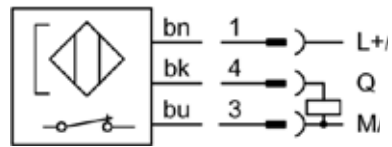

NPN NO

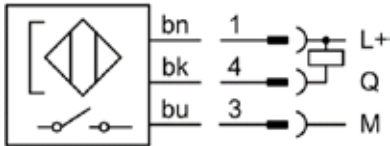

NPN NC

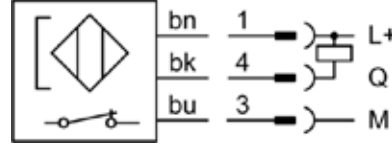

Reed NO 3-wire

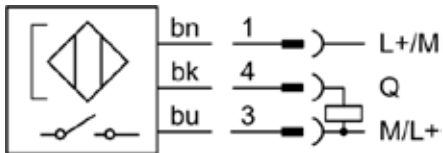

bn: brown  
 bk: black  
 bu: blue  
 Q: load  
 M: Mass  
 L+: Power

Reed NO 2-wire

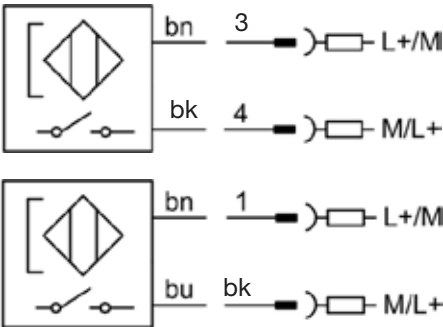

Reed NC 2-wire

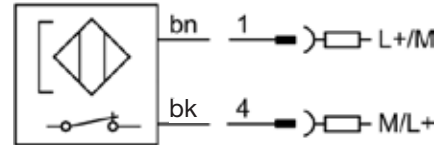

NAMUR NQ ATEX 1G, 1D

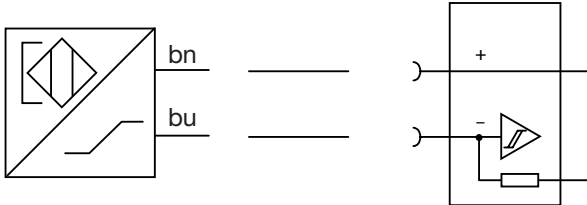

PNP NQ ATEX 3G, 3D

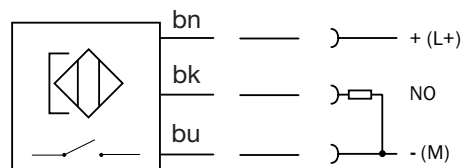

Pin assignment, M8 with knurled nut

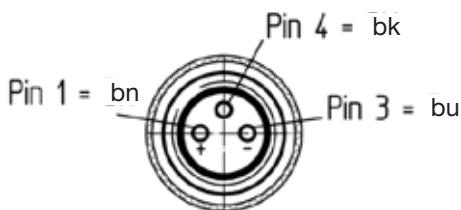

Flying leads

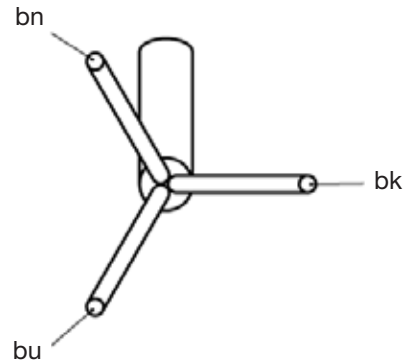

## Ordering Data

Square body design, Insert straight in T-slot, screw 1/4 turn

Output, Function, Cable & Supply Voltage	Order Code	Weight [g]	For Product Series
<b>With flying leads, PUR cable IP67</b>			
Electronic PNP-NC, with LED, 3-wire, 3 meter, 10-30 V DC	<b>P8SAGQFAX</b>	35	All Series
Electronic PNP-NC, with LED, 3-wire, 10 meter, 10-30 V DC	<b>P8SAGQFDX</b>	105	All Series
Electronic PNP-NO, with LED, 3-wire, 3 meter, 10-30 V DC	<b>P8SAGPFAX</b>	35	All Series
Electronic PNP-NO, with LED, 3-wire, 10 meter, 10-30 V DC	<b>P8SAGPFDX</b>	105	All Series
Electronic NPN-NC, with LED, 3-wire, 3 meter, 10-30 V DC	<b>P8SAGMFAX</b>	35	All Series
Electronic NPN-NC, with LED, 3-wire, 10 meter, 10-30 V DC	<b>P8SAGMFDX</b>	105	All Series
Electronic NPN-NO, with LED, 3-wire, 3 meter, 10-30 V DC	<b>P8SAGNFAX</b>	35	All Series
Electronic NPN-NO, with LED, 3-wire, 10 meter, 10-30 V DC	<b>P8SAGNFDX</b>	105	All Series
Electric Reed-NO, with LED, 3-wire, 3 meter, 5-30 V AC/DC	<b>P8SAGSFAX</b>	35	All Series
Electric Reed-NO, with LED, 3-wire, 10 meter, 5-30 V AC/DC	<b>P8SAGSFDX</b>	105	All Series
Electric Reed-NO, with LED, 2-wire, 3 meter, 5-30 V AC/DC	<b>P8SAGRFAFX</b>	35	All Series
Electric Reed-NO, with LED, 2-wire, 10 meter, 5-30 V AC/DC	<b>P8SAGRFDX</b>	105	All Series
Electric Reed-NO, with LED, 2-wire, 3 meter, 5-230 V AC/DC	<b>P8SAGRFAFX2</b>	35	All Series
Electric Reed-NO, with LED, 2-wire, 10 meter, 5-230 V AC/DC	<b>P8SAGRFDX2</b>	105	All Series
Electric Reed-NC, No LED, 2-wire, 3 meter, 5-120 V AC/DC	<b>P8SAGEFFX1</b>	35	All Series
Electric Reed-NC, No LED, 2-wire, 10 meter, 5-120 V AC/DC	<b>P8SAGEFRX1</b>	105	All Series

<b>With flying leads, PVC cable IP67</b>			
Electric Reed-NO, with LED, 3-wire, 3 meter, 5-30 V AC/DC	<b>P8SAGSFLX</b>	35	All Series
Electric Reed-NO, with LED, 2-wire, 3 meter, 5-120 V AC/DC	<b>P8SAGRFLX1</b>	35	All Series
Electric Reed-NO, with LED, 2-wire, 3 meter, 5-230 V AC/DC	<b>P8SAGRFLX2</b>	35	All Series
Electronic PNP-NC, with LED, 3-wire, 3 meter, 10-30 V DC	<b>P8SAGQFLX</b>	35	All Series
Electronic PNP-NO, with LED, 3-wire, 3 meter, 10-30 V DC	<b>P8SAGPFLX</b>	35	All Series

<b>With M8 knurled screw, PUR cable IP67</b>			
Electronic PNP-NC, with LED, 3-wire, 0,3 meter, 10-30 V DC	<b>P8SAGQCHX</b>	15	All Series
Electronic PNP-NO, with LED, 3-wire, 0,3 meter, 10-30 V DC	<b>P8SAGPCHX</b>	15	All Series
Electronic NPN-NC, with LED, 3-wire, 0,3 meter, 10-30 V DC	<b>P8SAGMCHX</b>	15	All Series
Electronic NPN-NO, with LED, 3-wire, 0,3 meter, 10-30 V DC	<b>P8SAGNCHX</b>	15	All Series
Electric Reed-NO, with LED, 3-wire, 0,3 meter, 5-30 V AC/DC	<b>P8SAGSCHX</b>	15	All Series
Electric Reed-NC, No LED, 2-wire, 0,3 meter, 5-30 V AC/DC	<b>P8SAGECNX</b>	15	All Series
Electric Reed-NO, with LED, 2-wire, 0,3 meter, 5-30 V AC/DC	<b>P8SAGRCHX</b>	15	All Series

<b>For ATEX IP67</b>			
Electronic PNP-NO, with LED, 3-wire, 3 meter, 10-26 V DC, PUR	<b>P8SAGPFAXS</b>	35	ATEX Series 3G, 3D
NAMUR-NO, with LED, 2-wire, 5 meter, 8,2-20 V DC, PVC	<b>P8SAGDFMXW *</b>	55	ATEX Series 1G, 1D
NAMUR-NO, with LED, 2-wire, 10 meter, 8,2-20 V DC, PVC	<b>P8SAGDFTXW *</b>	105	ATEX Series 1G, 1D

**Note:**

-30 to +80 °C (PUR cable) | -30 to +70 °C (PVC cable) | -25 to +80 °C (NAMUR 1GD) | -20 to +50 °C (ATEX 3GD)

All sensors are with an adaptor for S-dovetail Parker type OSP grooves.

\* with an aluminium adaptor





## P8S Continuous Position Sensors

Many applications require more than just end of stroke sensing of an actuator, but traditional methods of continuous sensing are expensive to implement. Parker's CPS (Continuous Position Sensing) series of the P8S sensor family enables quick, precise and contactless continuous position sensing of a piston in standard Sensors. This offers an outstanding price/performance ratio.

### Product Overview

P8S Continuous Position Sensors detect continuously the position of the piston of pneumatic cylinders using a direct, non-contact technology along the length of the sensors, measuring ranges from 32 to 256 mm. They can be mounted in T-slots without the need for additional accessories for cylinders built with common T-slot dimensions. Mounting on other cylinder types ie round cylinders type is possible with adaptors. The sensor settings can be adjusted during installation and during operation later on, using a teach button or, depending on the variant, using IO-Link. The sensors continuously supply data via analogue outputs or IO-Link. Analogue position sensors, for current or voltage, have a voltage output of 0 V ... 10 V as well as a current output of 4 mA ... 20 mA. It enables flexible machine concepts making it possible to solve tasks in areas such as quality monitoring and process control in conjunction with pneumatic cylinders. This continuous transfer of position data upgrades the functionality of the pneumatic cylinders by making them more intelligent and as a result, more versatile.

### Technical Data

<b>Cylinder type:</b>	Profile with T-slot
<b>Installation:</b>	Drop in, fixed by allen key 1.5 mm
<b>Measuring range:</b>	32 to 256 mm depending on type <sup>1)</sup>
<b>Housing length:</b>	45 to 269 mm depending on type
<b>Output Function:</b>	Analogue   IO-Link
<b>Analogue output (voltage):</b>	0 to 10 V   -
<b>Analogue output (current):</b>	4 to 20 mA   -
<b>Teach-in:</b>	Yes
<b>Enclosure rating:</b>	IP 67 (according to EN 60529)
<b>Supply Voltage:</b> <sup>2)</sup>	15 to 30 V DC
<b>Power consumption:</b> <sup>3)</sup>	<= 22 mA (analogue)   <= 25 ma (IO-Link)
<b>Max load resistance:</b> <sup>4)</sup>	<= 500 Ω
<b>Min load resistance:</b> <sup>5)</sup>	<= 2 kΩ
<b>Protection class:</b>	III
<b>Time delay before availability:</b>	1.5 s
<b>Required magnetic field sensitivity:</b>	3 mT / 2 mT (Analogue)   3 mT (IO-Link)
<b>Resolution:</b> <sup>6)</sup>	0.03% full scale range (max >=0.05 mm)
<b>Linearity error:</b> <sup>7)</sup>	0.3 mm
<b>Repeat accuracy:</b> <sup>8)</sup>	0.06% full scale range (>= 0.1 mm)
<b>Sampling rate:</b> <sup>9)</sup>	1 ms
<b>Indication LED colour:</b>	Yellow (Analogue)
<b>Reserve polarity protection:</b>	Yes (Analogue)
<b>Short circuit protection:</b>	Yes (Analogue)
<b>Ambiant operating temperature range:</b>	-20 to +70 °C (PUR cable)
<b>Shock and vibration resistance:</b>	30 g 11 ms / 10 ... 55 Hz, 1 mm
<b>EMC:</b> <sup>10)</sup>	According to EN 60947-5-2
<b>International standard:</b>	CE   C UL US   CCC (not applicable)   RoHs   IO-Link
<b>UL file No:</b>	On request
<b>Housing material:</b>	Plastic polyamid PA12
<b>Screw material:</b>	Stainless steel
<b>Cable material:</b>	PUR (Polyurethane)
<b>Conductor cross-section:</b>	0.08 mm <sup>2</sup>
<b>Connector:</b>	M12 (IO-Link) or M8 (Analogue)



<sup>1)</sup> ± 1 mm

<sup>2)</sup> Reverse-polarity protected, operation in short-circuit protected network: max. 8 A.

<sup>3)</sup> Without load

<sup>4)</sup> Power output, at 24 V

<sup>5)</sup> Voltage output

<sup>6)</sup> FSR: Full Scale Range; max. measuring range.

<sup>7)</sup> At 25 °C, linearity error (maximum deviation) depending on response curve and minimal deviation function.

<sup>8)</sup> At 25 °C, repeatability magnet movement in one direction.

<sup>9)</sup> Only in standard mode, not in IO-Link mode.

<sup>10)</sup> The analogue measured value can deviate under transient conditions.

### Continuous Position Sensing

Analogue signal or IO-Link communication for linear cylinders many applications require more than just end of stroke sensing of an actuator, but traditional methods of continuous sensing are expensive and difficult to implement. Parker's CPS series of the P8S sensor family enables quick, easy, precise, and contactless position sensing of a piston. This can be installed on a standard linear actuator and offers an outstanding price to performance ratio.

#### Product Features:

- Continuous position sensing
- IO-Link communication with M12 connector
- No modification to the actuator
- Analogue version with M8 connector
- 5 sizes with sensing ranges from 32 mm to 256 mm
- IP67 design suitable for any industrial application
- Yellow teach button for easy set-up

#### Technical specification:

1 ms sampling rate  
0.03% full scale resolution  
0.06% full scale repeatability  
0.3 mm Linearity error

#### How it works:

The CPS product detects the position of an actuator via the magnet on the piston. The sensor settings can easily be adjusted during installation using the yellow teach button or during operation over the IO-Link communication. This upgrades the functionality of the pneumatic actuator by making it more intelligent and versatile in support of the Industry 4.0 initiative.

#### How it connects:

Analogue version has a M8 connector and a voltage output of 0-10V as well as a current output of 4-20mA. IO-Link version has a M12 connector and transmits position via 2 bytes of process input data and also allows for parameter control of measuring range and locking of the teach button. It can be controlled by Class A or Class B IO-Link Masters.



#### How it installs:

The Parker CPS requires the use of a magnetic piston. The product will fit T-slot cylinders without any additional mounting hardware.

#### Without Adaptor:

Direct drop-in T-slot  
T-slot dimensions [mm ± 0.1]

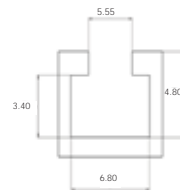

- 1) Pivot sensor into the slot
- 2) Teach the CPS unit the desired measuring range
- 3) Tighten set screws

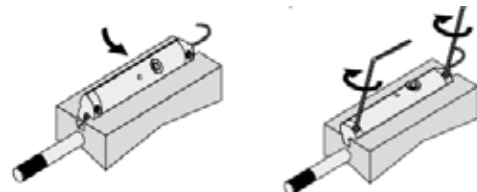

Dimensions in mm (inch)

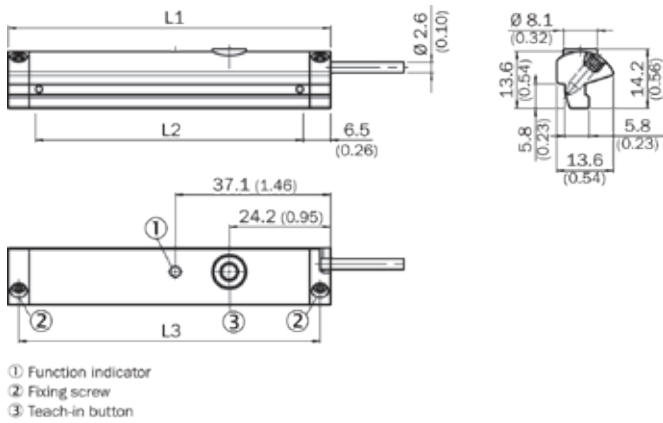

Order Code				
L1	L2 *	L3	Analogue	IO-Link
45	32	40	<b>P8SAGACHA</b>	<b>P8SAGHMHA</b>
77	64	72	<b>P8SAGACHB</b>	<b>P8SAGHMHB</b>
141	128	136	<b>P8SAGACHD</b>	<b>P8SAGHMHD</b>
205	192	200	<b>P8SAGACHF</b>	<b>P8SAGHMHF</b>
269	256	264	<b>P8SAGACHH</b>	<b>P8SAGHMHH</b>

\*L2 equal to the measuring range

Note:

PUR cable with M12 (IO-Link) or M8 (Analogue) male connector knurled nut, 4-pin, 0,3 meter length. Please consult for measuring range 96, 160 & 224 mm.

Connection type and diagram

IO Link version

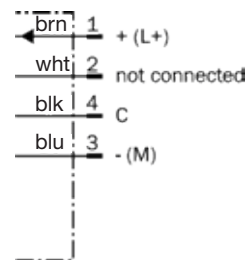

PUR 0.3 meter length with M12 male connector knurled nut, 4-pin

Analogue version

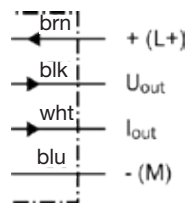

PUR 0.3 meter length with M8 male connector knurled nut, 4-pin

Ordering Data  
Drop in in T-slot

Output	Measuring length	Configuration Option	Order Code	Weight [g]	For product series
Analogue	32 mm	Teach Button	<b>P8SAGACHA</b>	16	With T-slot groove *
	64 mm		<b>P8SAGACHB</b>	26	
	128 mm		<b>P8SAGACHD</b>	46	
	192 mm		<b>P8SAGACHF</b>	66	
	256 mm		<b>P8SAGACHH</b>	86	
IO-Link	32 mm	Teach Button or IO-Link parameter	<b>P8SAG HMHA</b>	20	With T-slot groove *
	64 mm		<b>P8SAGHMHB</b>	30	
	128 mm		<b>P8SAGHMHD</b>	50	
	192 mm		<b>P8SAGHMHF</b>	70	
	256 mm		<b>P8SAGHMHH</b>	90	

\* Required magnetic field sensitivity: 3mT / -2 mT (Analogue) / 3mT (IO-Link)

Note:

PUR cable with M12 (IO-Link) or M8 (Analogue) male connector knurled nut, 4-pin, 0,3 meter length. Please consult for measuring range 96, 160 & 224 mm.

Mountings and brackets

For products series	Oder code	Weight [g]
Tie rods, VRS/VRA	<b>P8S-TMA0X</b>	65
Tie rods, P1D-T Ø 32-100	<b>P8S-TMA07</b>	10
Tie rods, P1D-T Ø 125-320	<b>P8S-TMA08</b>	32
T-Slot OSP Ø 10	<b>8872FIL</b>	3
T-Slot P Series Ø 16	<b>8865FIL</b>	4
T-Slot P Series Ø 25-80	<b>8866FIL</b>	5
Round cylinder Ø10-25	<b>P8S-TMC01</b>	27
Round cylinder Ø 32-63	<b>P8S-TMC02</b>	29
Round cylinder Ø 80-125	<b>P8S-TMC03</b>	32
S-Dovetail OSP, pack of 10	<b>P8S-TMA09</b>	10

Ambient temperature -30 to +80 °C

All mountings can be moved on the cylinder body before screwing in place and then putting sensors in the slots.

Dimensions in mm (inch)

P8S-TMC01, 02 & 03

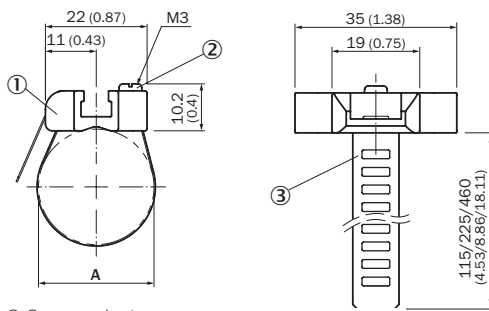

- ① Sensor adaptor
- ② Fixing screw
- ③ Strap

Oder code	D [mm]	
<b>P8S-TMC01</b>	8 to 25	Clamping ring in nickel silver, screw in stainless steel, sensor mounting zinc diecast
<b>P8S-TMC02</b>	32 to 63	
<b>P8S-TMC03</b>	80 to 130	

P8S-TMA0X

(Zinc diecast, zinc plated screws.)

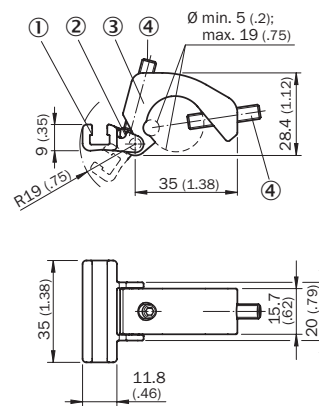

- ① Sensor adaptor with T-Slot
- ② Fixing for cable < Ø 3.2 mm (0.126 inch)
- ③ Cylinder adaptor
- ④ Mounting screws M5

P8S-TMA07

(anodised aluminium, zinc plated screws)  
Tie-Rods Cylinders Ø 32 to 100 mm

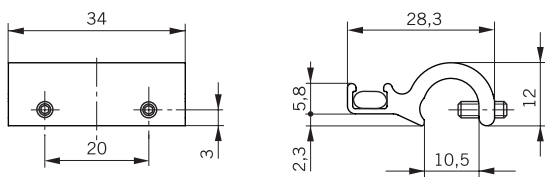

P8S-TMA08

(anodised aluminium, zingued screws)  
Tie-Rods Cylinders Ø 125 to 320 mm

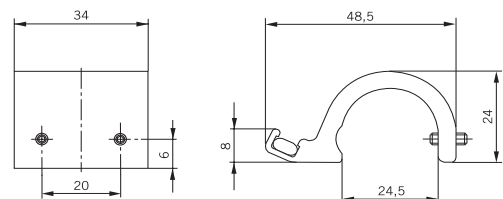

## Male connectors for connecting cables

Cable connectors for producing your own connecting cables. The connectors can be quickly attached to the cable without special tools. Only the outer sheath of the cable is removed. The connectors are available for M8 screw connector and meet protection class IP65.

### Technical Data

<b>Operating voltage:</b>	max. 32 V AC/DC
<b>Operating current per contact:</b>	max. 4 A
<b>Connection cross section:</b>	0.25... 0.5 mm <sup>2</sup> (conductor diameter min 0.1 mm)
<b>Protection class:</b>	IP65 and IP67 when plugged and screwed down (EN 60529)
<b>Temperature range:</b>	- 25... + 85°C

Connector	Weight kg	Order Code
M8 screw connector		<b>P8CS0803J</b>
M12 screw connector	0.022	<b>P8CS1204J</b>



## Cables to extend cable sensor lengths with M8\*

Description	Order Code	Weight [g]	For Product Series
Cable flex PVC 3 meter with 8mm snap-in connector / flying leads	<b>9126344341</b>	70	P8S Sensors with M8
Cable flex PVC 10 meter with 8mm snap-in connector / flying leads	<b>9126344342</b>	210	P8S Sensors with M8
Cable PUR 3 meter with 8mm snap-in femelle connector / flying leads	<b>9126344345</b>	70	P8S Sensors with M8
Cable flex PUR 10 meter with 8mm snap-in connector / flying leads	<b>9126344346</b>	210	P8S Sensors with M8
Cable PVC 2.5 meter with M8 screw connector / flying leads	<b>KC3102</b>	60	P8S Sensors with knurled M8
Cable PVC 5 meter with M8 screw femelle connector / flying leads	<b>KC3104</b>	120	P8S Sensors with knurled M8

\*Note: not applicable for P8S CPS Sensors as no cable available

## Pneumatic sensor for Tie-Rods Cylinders

An ideal solution where a direct pneumatic signal is wanted from a cylinder sensor to a pneumatic control system, for example. This could be a machine or device in which only compressed air is available, and an electricity supply to normal cylinder sensors would involve serious problems or considerable expense.

### Function:

Non-contacting sensing of a pneumatic cylinder, triggering an output signal (conn. 2) from the integrated 3/2 NC valve, which is activated by a magnetic field or iron core and has a return spring. If more than one sensor is used with a cylinder there must be a distance of at least 20 mm between sensors to prevent them influencing each other.

To avoid interference, there must be a minimum spacing of 15 mm to steel details.

The outlet (conn. 3) must not be blocked or restricted as this can impair the function of the sensor.

The sensor is fastened to the cylinder using the special sensor fixing.

### Technical data:

Working pressure:	min 2 to max 6 bar
Temperature:	-15 to +60 °C
Air quality:	3.4.3 to ISO 8573-1 (must be oil free)
Function:	3/2 NC valve
Flow:	40 NI per minute
Connection:	for plastic pipe with 2,5-3 mm internal diameter
Activation distance:	for magnet: min 9 mm
Activation distance:	for Fe: approx. 2 mm
Repetition accuracy:	+/- 0.2 mm
Cylinder velocity:	max 1 m/s (depends on magnetic field, interference from steel in environment, signal length requirement from control system...)
Distance between sensors:	min 20 mm
Distance from sensor to steel details:	min 15 mm
Fixing:	with sensor fixing or with an M4 thread in case
Sensing:	non-contacting (also through a wall of non-magnetic material)

### Dimensions (mm)

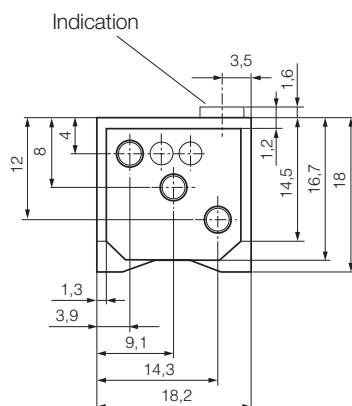

Active surface for sensing iron core

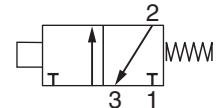
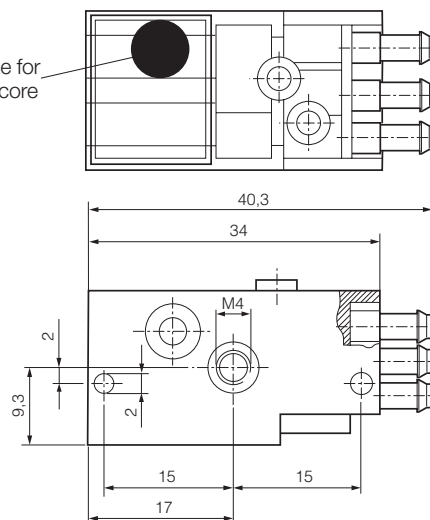

Description	Weight [kg]	Order code
Pneumatic sensor	0.02	<b>P8S-A34X</b>
Cylinder fixing bore Ø32 to Ø125 mm	0.01	<b>P8S-AMA1</b>

### Cylinder fixing - Tie-Rods Cylinders Ø 32 to 100 mm

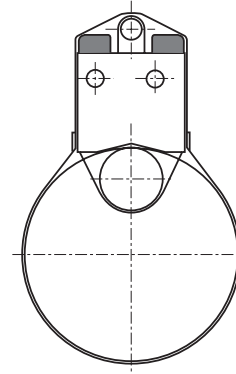

# Parker Worldwide

## Europe, Middle East, Africa

**AE – United Arab Emirates,** Dubai  
Tel: +971 4 8127100  
parker.me@parker.com

**AT – Austria,** Wiener Neustadt  
Tel: +43 (0)2622 23501-0  
parker.austria@parker.com

**AT – Eastern Europe,** Wiener Neustadt  
Tel: +43 (0)2622 23501 900  
parker.easteurope@parker.com

**AZ – Azerbaijan,** Baku  
Tel: +994 50 2233 458  
parker.azerbaijan@parker.com

**BE/LU – Belgium,** Nivelles  
Tel: +32 (0)67 280 900  
parker.belgium@parker.com

**BG – Bulgaria,** Sofia  
Tel: +359 2 980 1344  
parker.bulgaria@parker.com

**BY – Belarus,** Minsk  
Tel: +48 (0)22 573 24 00  
parker.poland@parker.com

**CH – Switzerland,** Etoy  
Tel: +41 (0)21 821 87 00  
parker.switzerland@parker.com

**CZ – Czech Republic,** Klecany  
Tel: +420 284 083 111  
parker.czechrepublic@parker.com

**DE – Germany,** Kaarst  
Tel: +49 (0)2131 4016 0  
parker.germany@parker.com

**DK – Denmark,** Ballerup  
Tel: +45 43 56 04 00  
parker.denmark@parker.com

**ES – Spain,** Madrid  
Tel: +34 902 330 001  
parker.spain@parker.com

**FI – Finland,** Vantaa  
Tel: +358 (0)20 753 2500  
parker.finland@parker.com

**FR – France,** Contamine s/Arve  
Tel: +33 (0)4 50 25 80 25  
parker.france@parker.com

**GR – Greece,** Athens  
Tel: +30 210 933 6450  
parker.greece@parker.com

**HU – Hungary,** Budaörs  
Tel: +36 23 885 470  
parker.hungary@parker.com

**IE – Ireland,** Dublin  
Tel: +353 (0)1 466 6370  
parker.ireland@parker.com

**IL – Israel**  
Tel: +39 02 45 19 21  
parker.israel@parker.com

**IT – Italy,** Corsico (MI)  
Tel: +39 02 45 19 21  
parker.italy@parker.com

**KZ – Kazakhstan,** Almaty  
Tel: +7 7273 561 000  
parker.easteurope@parker.com

**NL – The Netherlands,** Oldenzaal  
Tel: +31 (0)541 585 000  
parker.nl@parker.com

**NO – Norway,** Asker  
Tel: +47 66 75 34 00  
parker.norway@parker.com

**PL – Poland,** Warsaw  
Tel: +48 (0)22 573 24 00  
parker.poland@parker.com

**PT – Portugal**  
Tel: +351 22 999 7360  
parker.portugal@parker.com

**RO – Romania,** Bucharest  
Tel: +40 21 252 1382  
parker.romania@parker.com

**RU – Russia,** Moscow  
Tel: +7 495 645-2156  
parker.russia@parker.com

**SE – Sweden,** Spånga  
Tel: +46 (0)8 59 79 50 00  
parker.sweden@parker.com

**SL – Slovenia,** Novo Mesto  
Tel: +386 7 337 6650  
parker.slovenia@parker.com

**TR – Turkey,** Istanbul  
Tel: +90 216 4997081  
parker.turkey@parker.com

**UA – Ukraine,** Kiev  
Tel: +48 (0)22 573 24 00  
parker.poland@parker.com

**UK – United Kingdom,** Warwick  
Tel: +44 (0)1926 317 878  
parker.uk@parker.com

**ZA – South Africa,** Kempton Park  
Tel: +27 (0)11 961 0700  
parker.southafrica@parker.com

## North America

**CA – Canada,** Milton, Ontario  
Tel: +1 905 693 3000

**US – USA,** Cleveland  
Tel: +1 216 896 3000

## Asia Pacific

**AU – Australia,** Castle Hill  
Tel: +61 (0)2-9634 7777

**CN – China,** Shanghai  
Tel: +86 21 2899 5000

**HK – Hong Kong**  
Tel: +852 2428 8008

**IN – India,** Mumbai  
Tel: +91 22 6513 7081-85

**JP – Japan,** Tokyo  
Tel: +81 (0)3 6408 3901

**KR – South Korea,** Seoul  
Tel: +82 2 559 0400

**MY – Malaysia,** Shah Alam  
Tel: +60 3 7849 0800

**NZ – New Zealand,** Mt Wellington  
Tel: +64 9 574 1744

**SG – Singapore**  
Tel: +65 6887 6300

**TH – Thailand,** Bangkok  
Tel: +662 186 7000

**TW – Taiwan,** Taipei  
Tel: +886 2 2298 8987

## South America

**AR – Argentina,** Buenos Aires  
Tel: +54 3327 44 4129

**BR – Brazil,** Sao Jose dos Campos  
Tel: +55 800 727 5374

**CL – Chile,** Santiago  
Tel: +56 2 623 1216

**MX – Mexico,** Toluca  
Tel: +52 72 2275 4200

European Product Information Centre

Free phone: 00 800 27 27 5374

(from AT, BE, CH, CZ, DE, DK, EE, ES, FI, FR, IE, IL, IS, IT, LU, MT, NL, NO, PL, PT, RU, SE, SK, UK, ZA)

